

**DOUBLE CHECK DETECTOR**

Use when on-site system includes fire hydrants (4"-10" only)

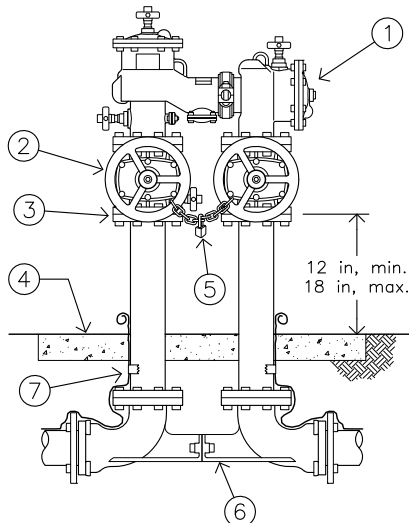

**DOUBLE CHECK**

No on-site hydrants (2"-10")

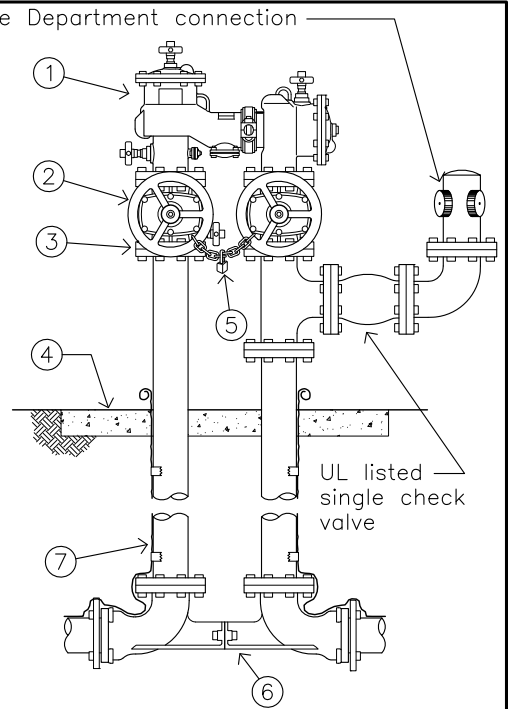

**DOUBLE CHECK W/ FDC**

When requested by Fire Department (4"-10" only)

**GENERAL NOTES:**

- A. All fittings and risers smaller than 3" diameter shall be copper or brass. Fittings and risers larger than 3" shall be ductile iron pipe internally cement lined for fire service and wrapped with two layers of UPC listed plastic tape minimum 1½" or coated with Henry's #204 plastic roof cement or an approved equal.
- B. Materials shall be UL listed for fire service.
- C. Materials shall be inspected by Fire Department prior to installation.
- D. Fire line shall be tested in accordance with Section 76, "Waterlines" of the City Standard Specifications. No connections may be made until water samples have been tested and approved.
- E. Location of double check and FDC shall be approved by Fire Department prior to placement.
- F. Wrap bolts with ¼" plastic sheathing prior to placement of thrust blocks.
- G. Provide clearances around device per manufacturer's recommendations and adequate access for testing.
- H. When adequate space does not exist between the public right-of-way and the building face, the USC approved backflow prevention device may be installed inside the building on the fire sprinkler riser (refer to Engineering Standard #6590 for underground portion.) The backflow preventer shall be located no further than 20' from the street side property line. Other USC-approved devices may appear different than those shown. Exterior installations shall have OS&Y valves. Devices installed inside buildings may have indicating butterfly valves.

**NOTES:**

- ① Backflow preventer shall be approved by the University of Southern California Foundation for Cross-Connection Control and Hydraulic Research for the proposed application.
- ② Backflow preventer shall include OS&Y valves. Backflow preventers that are USC-approved with butterfly valves may be used with prior written approval of the Fire Marshall when installed inside a building. Each valve shall include tamper device for electronic monitoring. Junction boxes shall have tamper-proof screws.
- ③ All risers and above ground mainline fittings shall be flange type, epoxy coated inside or cement mortar lined.
- ④ Class 3 PCC pad, 4" thick, 12" minimum around risers, on 4" Class 3 Base.
- ⑤ Break-away padlock and chain between OS&Y valves, locked in open position.
- ⑥ Valve setter or PCC thrust blocks, Class 3, size as required for type of soil.
- ⑦ Tracer wire from street valve or double check assembly to hydrant and/or building sprinkler riser per Engineering Standard #6020.
- ⑧ Double Check Detector meters shall be supplied with registers that measure in "units" (100 cu. ft.).

*ANY MODIFICATION TO FIRE DEPARTMENT REQUIREMENTS MUST HAVE WRITTEN APPROVAL FROM THE FIRE DEPARTMENT.*

REVISIONS	BY	APP	DATE
Add Note 8	DVB	BL	10-07
Revised Notes A and H	MH	JDW	10-04
Revise Notes H & 1	DVB	BL	11-06
STANDARD CURRENT AS OF:		January 2010	



**DOUBLE CHECK BACKFLOW PREVENTER**  
2" to 10"